

EMC 單相 LED 電源雜訊抑制濾波器(雙 π 迴路)

EMC –Power Line Filter for 1-phase systems (two-stage) for LED

HUA Series, all-purpose filters to Protection Class B .

(0~250VAC 50/60HZ) OR (0~80VDC)

θ_a 40°C **EN55011/CLASS A EN55011/CLASS B**

CE

CONFORMS
TO IEC 60 950
UL 1283
EN 133200

The TL series power filter in line with EN55022/Class A and CISPR22/ Class B protection
 The two stage filter attenuation losses due to its high symmetry, particularly suitable for use in
 power quality requirements for high-end DC power supply LED power supply and output power.
 Whether AC or DC power supply filter has good filtering effect.

本 TL 系列電源濾波器符合 EN55011/ClassA 及 CISPR22/ ClassB 保護標準
 本雙極電源濾波器由於其高對稱衰減損失，特別適合用在對於電源品質要求很高的
 LED DC 電源供應器電源端與輸出端電源，無論電源供應器 輸入端 AC 電源濾波 或
 輸出端 DC 電源濾波皆有不錯的雜訊濾除效果。

Specification

Test Voltage (1 min) :L /Nto E 2000VAC/2250VDC

L to N 2500VDC

Insulation Resistance : L/N to E $\geq 3000M\Omega$

Current reduction above 40°C

ambient temperature: $I=I_n \sqrt{(85-\theta)/45}$ θ = operating

temperature

AC 電源濾波器規格



TYPE	I_n @ $\delta_a 40^\circ C$ [A]	U_{max} 50/60Hz [v]	Overload Current	Resistance L-L' $\pm 15\%$ [m Ω]	Power Dissipation total $\pm 15\%$ [W]	Max. leakage current @250v/60Hz [mA]	Temperature Rise $^\circ C$	Temperature Range $^\circ C$
HUA-9010-L103-TLA	3	0~250	1.5 $\times I_n$ 1 min. per hour	28	0.252	≤ 2	≤ 30	-25 ~ +85
HUA-9010-L106-TLA	6			23	0.828		≤ 30	-25 ~ +85
HUA-9010-L110-TLA	10			14.2	1.42		≤ 30	-25 ~ +85
HUA-9010-L120-TLA	20			5.8	2.32		≤ 30	-25 ~ +85

DC 電源濾波器規格

TYPE	In @ $\delta a 40^{\circ}C$ [A]	Umax 0Hz [v]	Overload Current	Resistance L-L' $\pm 15\%$ [m Ω]	Power Dissipation total $\pm 15\%$ [W]	Max. leakage current @80v/ 0Hz [mA]	Temperature Rise $^{\circ}C$	Temperature Range $^{\circ}C$
HUA-9010-L103-TLD	3	0~80	1.5 \times In 1 min. per hour	30	0.27	≤ 2	≤ 30	-25~+85
HUA-9010-L106-TLD	6			25	0.9		≤ 30	-25~+85
HUA-9010-L110-TLD	10			16	1.6		≤ 30	-25~+85
HUA-9010-L120-TLD	20			8	2.56		≤ 30	-25~+85

Order Types (訂購型號說明)

型號:HUA - 9010-L1□- TL □

- A:表示 AC 電源濾波用
- D:表示 DC 電源濾波用
- 表示 LED 專用/T-250 端子出線
- 03:表示 3A 額定電流
- 06:表示 6A 額定電流
- 20:表示 20A 額定電流

Circuit Diagram(電路圖)

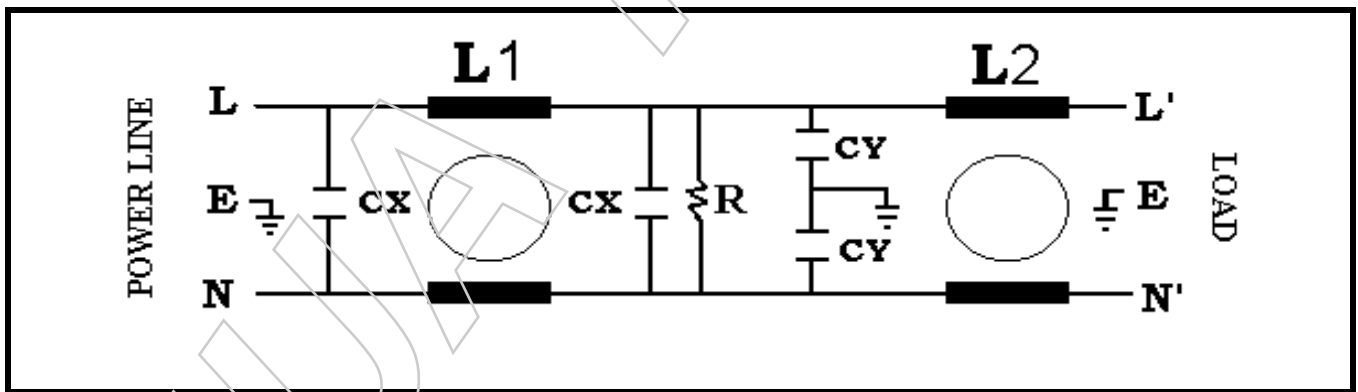

AC 電源濾波

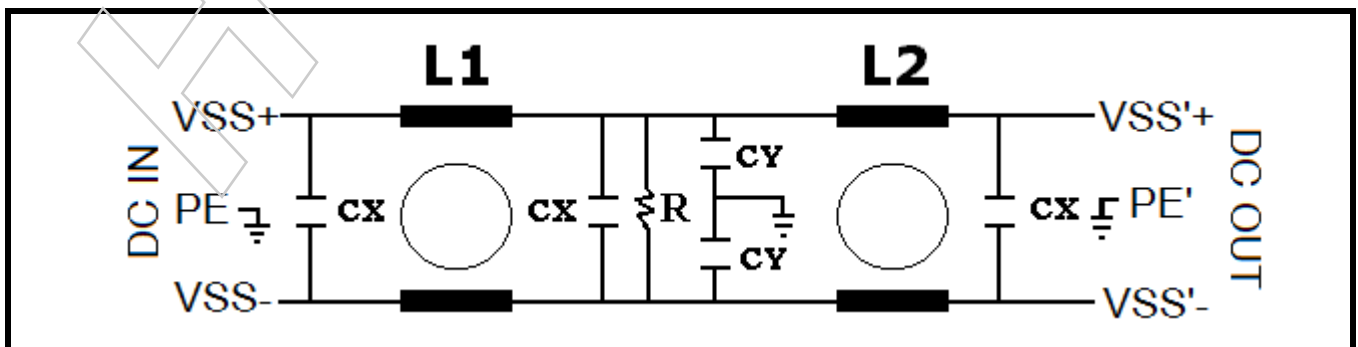

DC 電源濾波

Insertion loss (衰減值)

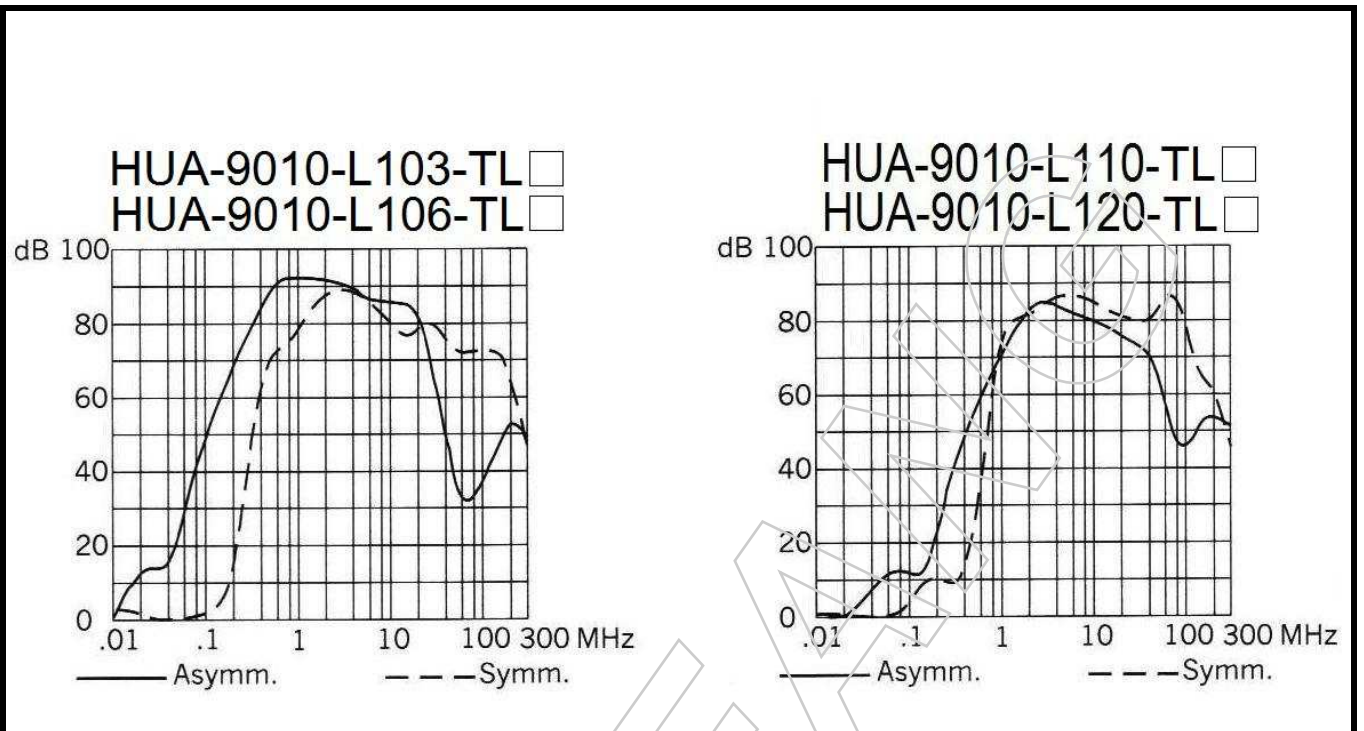

Dimension(mm) 外殼形式

